

eurobent
KEEP ROLLING

TILTEX

Tiltex
SYSTEM

INSTALLATION GUIDE



TABLE OF CONTENTS

1. SCOPE	3
2. ABOUT EUROBENT	5
3. ENVIRONMENTAL IMPACT	7
4. SUPPLY, PACKAGING AND LABELLING	9
5. UNLOADING, STORAGE AND TRANSPORTATION	11
5.1. Unloading	12
5.2. Storage	12
6. AFTER DELIVERY INSPECTION	13
7. EQUIPMENT RECOMMENDED ON SITE	15
8. PERSONAL PROTECTIVE EQUIPMENT	17
9. QUALIFICATION FOR INSTALLER	19
10. INSTALLATION	21
10.1. Subgrade preparation	22
10.2. Installation and positioning	22
10.3. Watering overlaps	22
10.4. Joining	22
10.5. Anchoring whole lined surface	23
10.6. Anchoring TILTEX on slope	24
10.7. Selection of suitable anchoring materials	24
10.8. Overlapping TILTEX Plus	26
11. INSPECTION	27
12. HYDRATING	29
13. EXAMPLES OF INSTALLATIONS	32
13.1. Erosion control	32
13.2. Slope protection	32
13.3. Slope stabilisation	32
13.4. Bund lining	32
13.5. Ditch lining	32
13.6. Geomembrane protection	32
13.7. Containment Pond	32
13.8. Suggestions for the right type of TILTEX to use for application	33
14. MAINTENANCE	34
15. TERMS AND CONDITIONS	36

SCOPE

01

SCOPE

The following installation recommendations are general guidelines for TILTEX GCCM (geosynthetic cementitious composite mat) installation. They are provided as a general statement and are not a direct substitute for specifications for the project. In the event of a discrepancy, the project specification will override these recommendations.

These installation guidelines are not intended to establish a specific procedure for all climatic, geographic, hydraulic, or topographic conditions that may exist at a particular installation site. Appropriate installation procedures for unusual site conditions should be modified as necessary to maintain the integrity of TILTEX and adjacent site. The information contained in this document has been prepared by Eurobent Sp. z o.o. and is, to the best of our knowledge, true and accurate.

The user of these guidelines should establish appropriate safety and health practices and determine the applicability

of legal restrictions prior to use.

Final determination of suitability for the intended application rests solely with on the user, who is responsible for proper installation of the TILTEX. This information is subject to change without notice. Eurobent does not warrant or assume responsibility for the results obtained from these installation guidelines or for the proper application of TILTEX in any project, as it is the designer's responsibility to determine what material is appropriate for a particular project.

These instructions should be read in relation to the contract specifications and drawings. They are intended to provide guidance in normal installation situations and are provided on the request. If you have questions about the design, unusual installation problems, or any concerns, contact your designer or Eurobent for further advice. In all situations, the installer is responsible for the installation.



SCOPE

ABOUT EUROBENT

02

ABOUT EUROBENT

Eurobent Sp. z o.o. is a Polish company from Lower Silesia.

Eurobent is a producer of Geosynthetic Liners and entered the GCL production market in 2008, then started to produce liners with other fillings, which led us to the production of cement-filled mats.

The company is a team of young, dynamically developing people. Thanks to the high standards of its products and the professional service Eurobent has earned the trust and respect of one of the largest Geosynthetic Liners consumers in the European market and beyond. At the same time, thanks to many years of experience in the field of geosynthetics production, the company has been able to develop invaluable knowledge in the production of Geosynthetic Liners, which has enabled them to become an innovative and acknowledged competitor on the international market.

The company consists of skilled staff committed to provide the best service and products available on the international marketplace.

Eurobent's laboratory technicians constantly undertake numerous tests on our products to ensure that their high standards are constantly maintained.

Eurobent is committed to constantly reviewing the service we provide, thus ensuring that we not only meet all of our customers' needs and requirements but exceed them. The company aims to provide the highest quality geosynthetic products and also ensure that it would be manufactured, stored and transported in the way to minimize their impact on the environment. The customers can be sure that they purchase an environmentally friendly product from a company that is dedicated and committed to environmental protection.



ABOUT EUROBENT

ENVIRONMENTAL IMPACT

03

ENVIRONMENTAL IMPACT

All materials used for the production of EUROBENT liners do not contain any hazardous or toxic substances and do not affect the environment in any way. No harmful substances are released to the EUROBENT liners in case of fire hazard.



ENVIRONMENTAL IMPACT

**SUPPLY,
PACKAGING
AND LABELLING**

04

SUPPLY, PACKAGING AND LABELLING

EUROBENT liners are labelled according to EN ISO 10320 for easy identification after unloading and during installation. Each roll shall be marked with the following information:

1. Manufacturer's name
2. Product identification
3. Roll number

TILTEX is usually provided in rolls with a width of 5,0 m and a length of 20 m. Rolls can be also offered in other dimensions, depending on customer needs. The range of possible widths is 1 m to 5.1 m, and they can have the length specified by the customer. Average roll diameter is approximately 60 cm, and the weight is approximately 1000 kg. EUROBENT liners are wound on plastic tubes with an inner diameter of 100 mm. Every roll is packed in a plastic UV resistant sleeve.



Each roll is equipped into a set of two belts. It is recommended while unloading from the truck to put a steel pipe inside to prevent bending of the roll.



**UNLOADING,
STORAGE AND
TRANSPORTATION**

05

UNLOADING, STORAGE AND TRANSPORTATION



5.1. Unloading

The party directly responsible for unloading the rolls should refer to this manual prior to arrival of the material in order to make sure they have proper unloading equipment and know the procedure. The unloading and on-site handling should be appropriately supervised. During the unloading procedure all material lot and roll numbers should be recorded and compared to the packing list. In addition, each roll of TILTEX should also be visually inspected to determine if there is no perforation in the packaging or other visual material damage.

The exact nature and extent of the damage should also be indicated on the CMR / Bill of Lading along with the specific lot and roll numbers of the damaged materials. Photos of the damaged goods on the truck are required.

Unloading the truck at the construction site is carried out either by forklifts, wheel loaders, excavators or by means of built-in truck cranes.

A suitable crossbeam can be used also for the unloading. The crossbeam pipe (with a maximum diameter of 8 cm) is

thrust through the core of the rolls and attached at the ends with chains, belts or ropes to the crossbeam. The unloading is carried out upwards.

If there is no crossbeam available, at least 2 belts are wound around the rolls. The unloading is carried out smoothly upwards or laterally via e.g. crane.

Another unloading option is a forklift, to which a stable mandrel is attached. The truck is unloaded from the back in this manner. Under no circumstances should the rolls be dragged from the truck since liners may be damaged significantly.

TILTEX may also be delivered in shipping containers. In these cases, different unloading equipment and techniques must be employed. Because of limited access to the rolls, it is usually necessary to utilize an extendable-boom forklift with a pole carpet (stinger) attachment.

The rolls are removed by inserting the stinger through the roll cores and lifting/pulling the rolls from the container. To each container we add several loading straps - thanks to that rolls can be tied up - it makes it easier to remove the rolls from the container.



5.2. Storage

TILTEX may be stored at a project site, provided that proper storage procedures are followed.

Firstly, a dedicated storage area should be identified. This area should be leveled, dry, well drained, and located away from high-traffic areas of the job site. In the warehouse and on site, liners should be placed on underlying material (wooden beams, pallets, plastic profiles etc.) to avoid unnecessary material wetting by rain during storage.

Rolls should not be stacked in more than 4 rolls high. Storage of material in a warehouse or on a construction site requires periodic inspection of the condition of the packaging. The polyethylene sleeves of TILTEX rolls should be examined for any obvious rips or tears. If the sleeve is damaged, check for water inside the packaging. Any water should be removed immediately and TILTEX should be checked to ensure that the curing process has not started. Sleeve damage should be repaired immediately with adhesive tape or additional plastic sheeting. At this point it is also recommended to examine the labels - if they were displaced in transit, they should be taped to the roll.

TILTEX should not be directly exposed to the elements during the storage. Cover all rolls with a plastic sheet or a tarpaulin. Do not remove the plastic sleeves prior to installation.

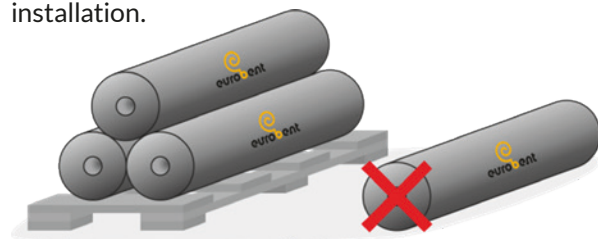
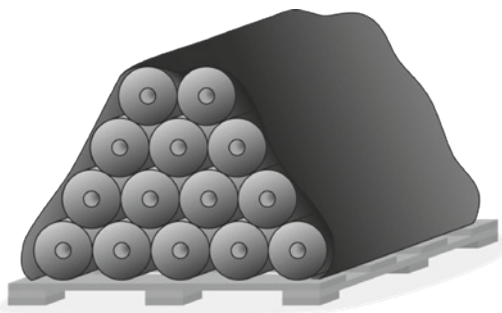

NOTE:

The temperature of the surrounding environment has no degrading effect on the quality of TILTEX liner.

AFTER DELIVERY INSPECTION

06

AFTER DELIVERY INSPECTION

1. Each roll shall be visually inspected when unloaded to determine if any packaging or material has been damaged during transit.
2. Repairs to damaged TILTEX shall be performed in accordance with installation manual:
 - a. Rolls with visible damage shall be marked and set aside for closer examination during deployment.
 - b. Minor rips or tears in the plastic packaging shall be repaired with moisture resistant gluing tape prior to being placed in storage to prevent moisture damage.
 - c. TILTEX rolls delivered to the project site shall be only those indicated on manufacturer internal test reports (ITR).

Preserve integrity and readability of roll labels.



AFTER DELIVERY INSPECTION

**EQUIPMENT
RECOMMENDED
ON SITE**

07

EQUIPMENT RECOMMENDED ON SITE

The QCA inspector shall verify that proper handling equipment exists which does not pose any danger to installation personnel or risk of damage or deformation to the liner material itself.

Suitable handling equipment is described below:

1. Spreader Bar Assembly – shall include both a core pipe or bar and a spreader beam. The core pipe shall be used to uniformly support the roll when inserted through the liner core while the spreader bar beam will prevent chains or straps from chafing the roll edges;
2. Stinger – a rigid pipe or rod with one end directly connected to a forklift or other handling equipment. If a stinger is used, it should be inserted to its full length into the roll to prevent excessive bending of the roll when lifted;
3. Straps – a properly structured and supported pole or “carpet puller” can be used to unload TILTEX rolls onsite. As an alternative, straps with appropriate lifting capacity, located across the roll, can be used as one of the method of lifting and unload TILTEX rolls;
4. Excavator (tracked or wheeled) or front-end loader. Equipment should be suitable for the anticipated load;
5. Carpet knife or safety knife;
6. Felt pens or other pens to write on geotextiles;
7. Measuring tape;
8. Broom;
9. Tape;
10. Geomembrane welding machine (only in case of TILTEX Plus);
11. A water source that will allow TILTEX to hydrate, according to the hydration instructions.



EQUIPMENT RECOMMENDED ON SITE

PERSONAL PROTECTIVE EQUIPMENT

08

PERSONAL PROTECTIVE EQUIPMENT

Respiratory, eye, hand and body protection may be recommended when working with TILTEX liner. Safety is key, so taking the necessary safety precautions is a must.



Safety Eye protection



Dust mask



Safety Hazard Clothing



Glove



PERSONAL PROTECTIVE EQUIPMENT

QUALIFICATION FOR INSTALLER

09

QUALIFICATION FOR INSTALLER

Recommendations:

The installation team must be familiar with geosynthetic liners installation guidelines and be trained in installation of it.

Installer shall have experience installing geosynthetic liners on at least 5 projects and have installed a minimum of 100 thousand m² of geosynthetic liners materials.

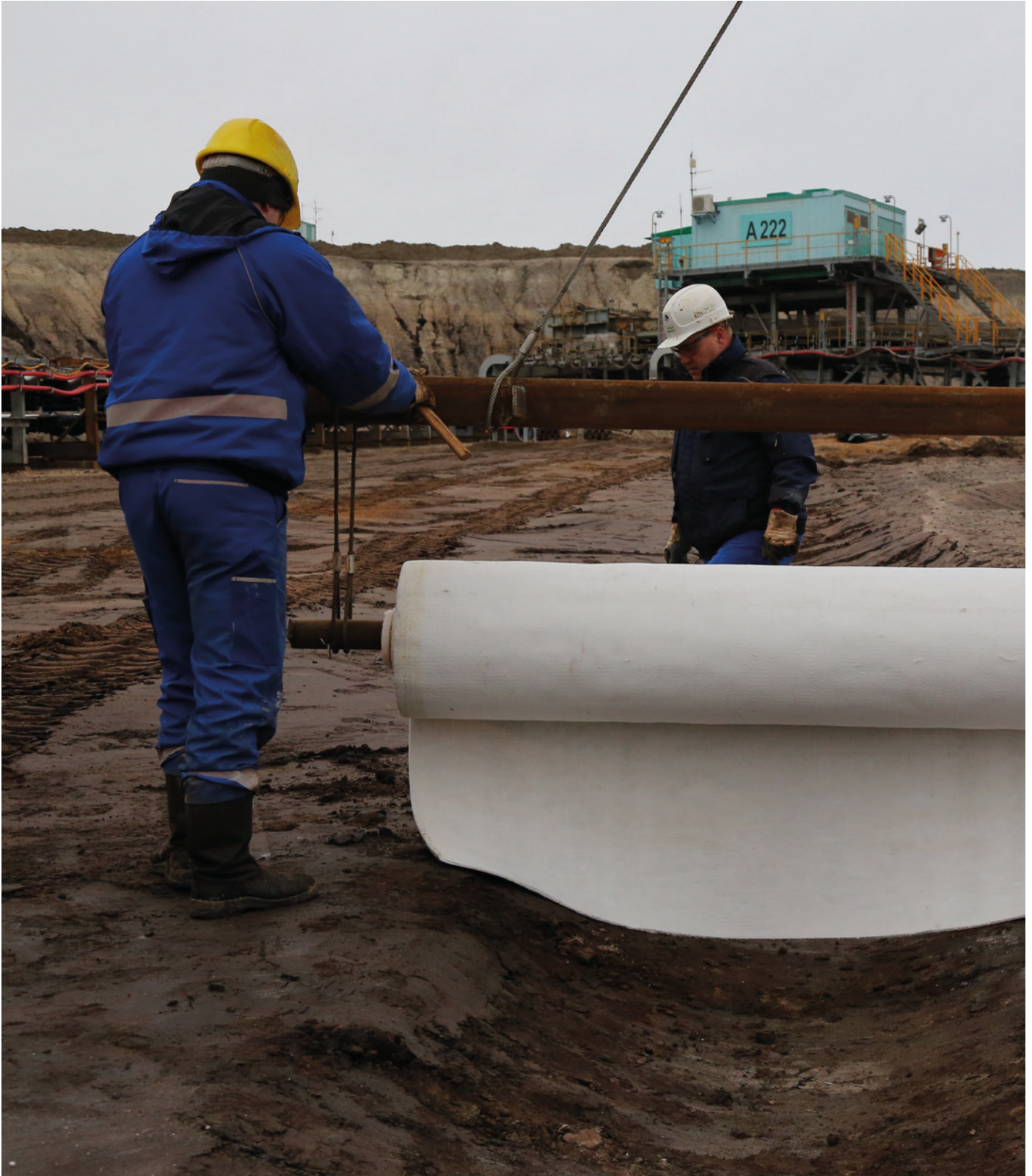

QUALIFICATION FOR INSTALLER

INSTALLATION

10

INSTALLATION



10.1. Subgrade preparation

TILTEX will fit the underlying surface shape, therefore any sharp rock, organic matter and other objects shall be removed. The trench should have an even profile for ease of future preservation. Avoid empty voids.

The subgrade should be compacted to a relative proctor of at least 90% (it can be checked by the sand cone method). TILTEX can also be used to reinforce existing concrete structures.

It is important that the substrate under the mat is hardened compacted and free from large and sharp objects and vegetation.

10.2. Installation and positioning

TILTEX shall be placed on the flat and smooth ground so that no wrinkles or folds appear. Unroll TILTEX liner into the supgrade profile. TILTEX Plus shall be arrayed with geomembrane facing down. Start on the lowest point of the trench and overlap against the slope of the channel in the direction of water flow (like roof tiles).

For easier handling and positioning it is recommended to provide a lifting device which allows to lift the rolls with a front end loader. The iron core may serve as a device for unloading as well as for installation of the liner.

The orientation of panels on slopes shall be parallel to the slope. The panels should be anchored to the trench at the top of the slope.

When setting subsequent layers ensure there is at least a 10 cm overlap between layers in the direction of water flow.

TILTEX Plus shall be arrayed with geomembrane facing down.

10.3. Watering overlaps

Water the area under the overlapped TILTEX sections. Once sprayed, the material remains flexible for 90 minutes. Hydration of the lower layer allows for thorough and proper hydration of the lower layer, which without this does not have access to sufficient water.

10.4. Joining

Stick screws or steel bars approx. 5 cm from the edge of the connection. Ensure they are sharp enough to penetrate the TILTEX. Nails length and spacing is dependable on soil conditions and application type – please contact Eurobent to select suitable materials and joining techniques. They should be applied at connections where possible to secure adjacent layers together. We recommend spacing the screws 20 cm apart.

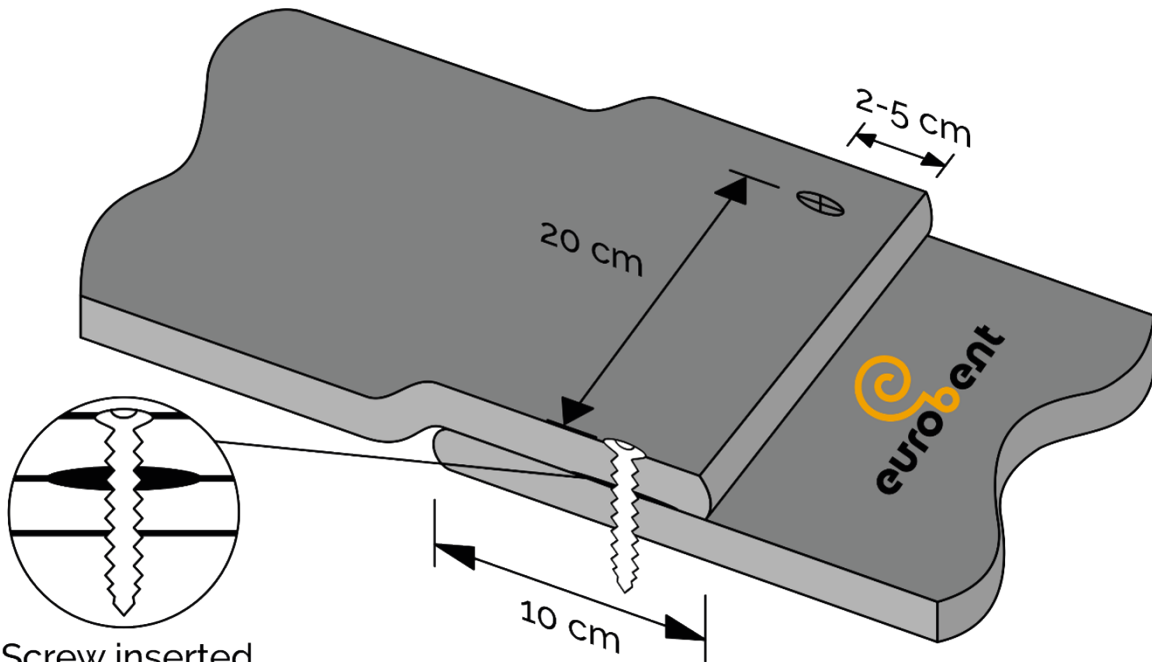

Screw inserted through sealant bead

10.5. Anchoring whole lined surface

Stick screws or steel bars approx. 5 cm from the edge of the connection.

Ensure they have enough sharp point to penetrate the concrete liner. Nails length and spacing is dependable on soil conditions and application type. They should be applied at connections where possible to secure adjacent layers together.

Anchoring can be done with different types of anchors, of which we recommend those shown in the figure below.

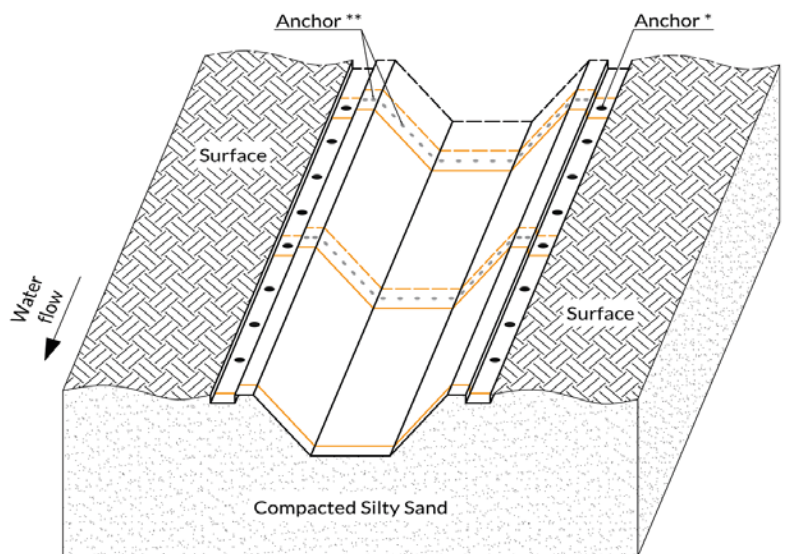

Anchor options	
*	**
<p>U-bar</p>	<p>TL-P4</p>
<p>J-pin</p>	

10.6. Anchoring TILTEX on the top of the slope

Stick screw the bolts or steel rods in the middle of the anchor trench in every 0,5 m.

Ensure they have enough sharp point to penetrate the concrete liner. Nails length and spacing is dependable on soil conditions and application type. They should be applied at connections where possible to secure adjacent layers together.

Anchoring can be done with different types of anchors, of which we recommend U-bars.

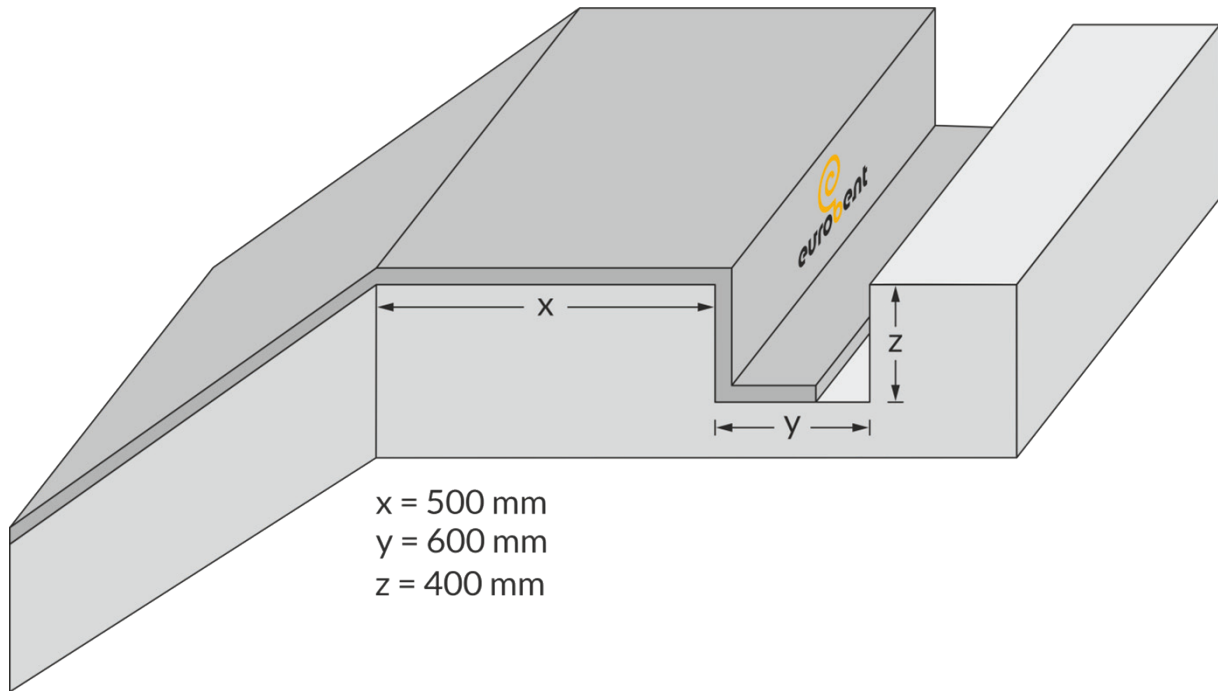

10.7. Selection of suitable anchoring materials

Depending on the substrate, we can offer several anchoring materials. If in doubt, contact Eurobent to choose the right one.

Anchoring to soil:

Anchor trench: The edges of the TILTEX are best buried in the soil. To do this, an anchor trench must be made to prevent the TILTEX panels from being washed up and carried away. Such anchoring is primarily required at the top and bottom of the slope, along ditches and channels. We recommend making the ditch 50 cm deep, 60 cm wide and at a safe distance from the top of the slope. Once the edge of the TILTEX has been placed in the trench, it should be anchored and backfilled with topsoil or poured with concrete.

Pins: Eurobent recommends Gripple pins, but other pins may also be used, provided their tip will allow them to penetrate the TILTEX surface and their head is sufficient to hold the TILTEX panels. The length and spacing of the pins should be selected individually according to the site's terrain and soil conditions.

Ground anchors: For heavy loads and steep slopes, ground anchors should be used. Eurobent recommends Gripple anchors, but others can also be used. The condition is that they are chosen correctly so that they can penetrate and hold the TILTEX. The length and type of anchors, as well as their placement, is selected individually for the installation site taking into account the terrain and soil conditions.



Anchoring to concrete:

Masonry bolts and anchors for concrete: To fix TILTEX to concrete, use standard screws, nails or masonry anchors whose heads will enable TILTEX to be held. Their length should be selected individually. The head should not be smaller than 15 mm.

Mortar: Mortar can be used on the joints and edges of the TILTEX panels. It will allow you to anchor like an anchor trench, and seal the overlaps. The mortar adheres very firmly to the fibrous surface of the TILTEX. It should be applied to the moistened TILTEX surface.

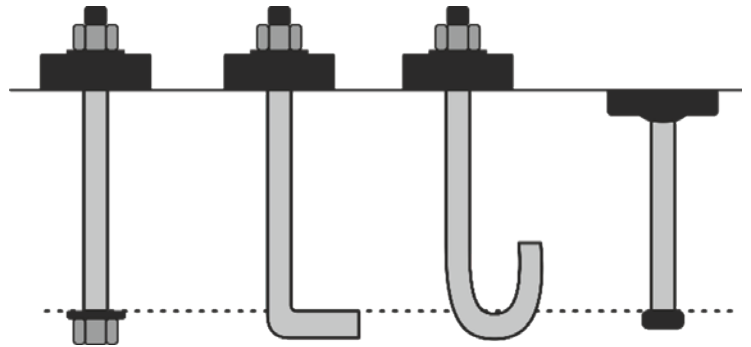

Anchoring to rock:

Rock bolts and anchors: On hard and rocky ground, use bolts or anchors suitable for it, the head of which allows the TILTEX to be held. The length and spacing of the anchors should be selected according to the pulling strength requirements and the design.

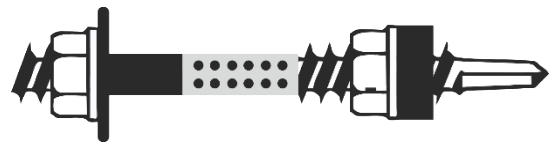

Anchoring to steel:

Technical screws: TILTEX should be fixed to the sheet metal with self-tapping screws whose head allows the TILTEX to be held. If the screw head is small, washers should be used to prevent the liner from dragging.



Rings: For fixing TILTEX on steel mesh (e.g. on gabions), use steel rings. Rings come in different sizes and the selection of the correct one should be determined by the conditions on site. Hand-mounted rings or rings using a power tool can be used.

Anchoring to wood:

Screws, staples, nails or glue: TILTEX can be fixed to wood using one of the conventional fixing materials. TILTEX is a geosynthetic product that behaves like a non-woven fabric before being soaked. The anchoring material should be selected to protect the TILTEX from pulling out, so the head should be large enough. We recommend a minimum of 15 mm, or the use of a shim.



10.8. Overlapping TILTEX Plus

1. TILTEX shall be folded so that the geomembrane can be visible.
2. The surface of the geomembrane shall be cleaned using acetone or similar preparation. This action secures the integrity of combining. Clean membrane surface before combining is a must.
3. The geomembrane of the panel 1 shall be covered with geomembrane of the panel 2, creating overlap.
4.
 - i. Welding shall be done in accordance with geomembrane welding principles. Welding is recommended for geomembranes thicker than 0.5 mm.
 - ii. For thin films, where welding cannot be used, use adhesive tape to join the individual panels together.
5. After combining the geomembranes, TILTEX shall be unfolded, covering the geomembranes.
6. The panel 2 shall be unfolded, covering first panel.

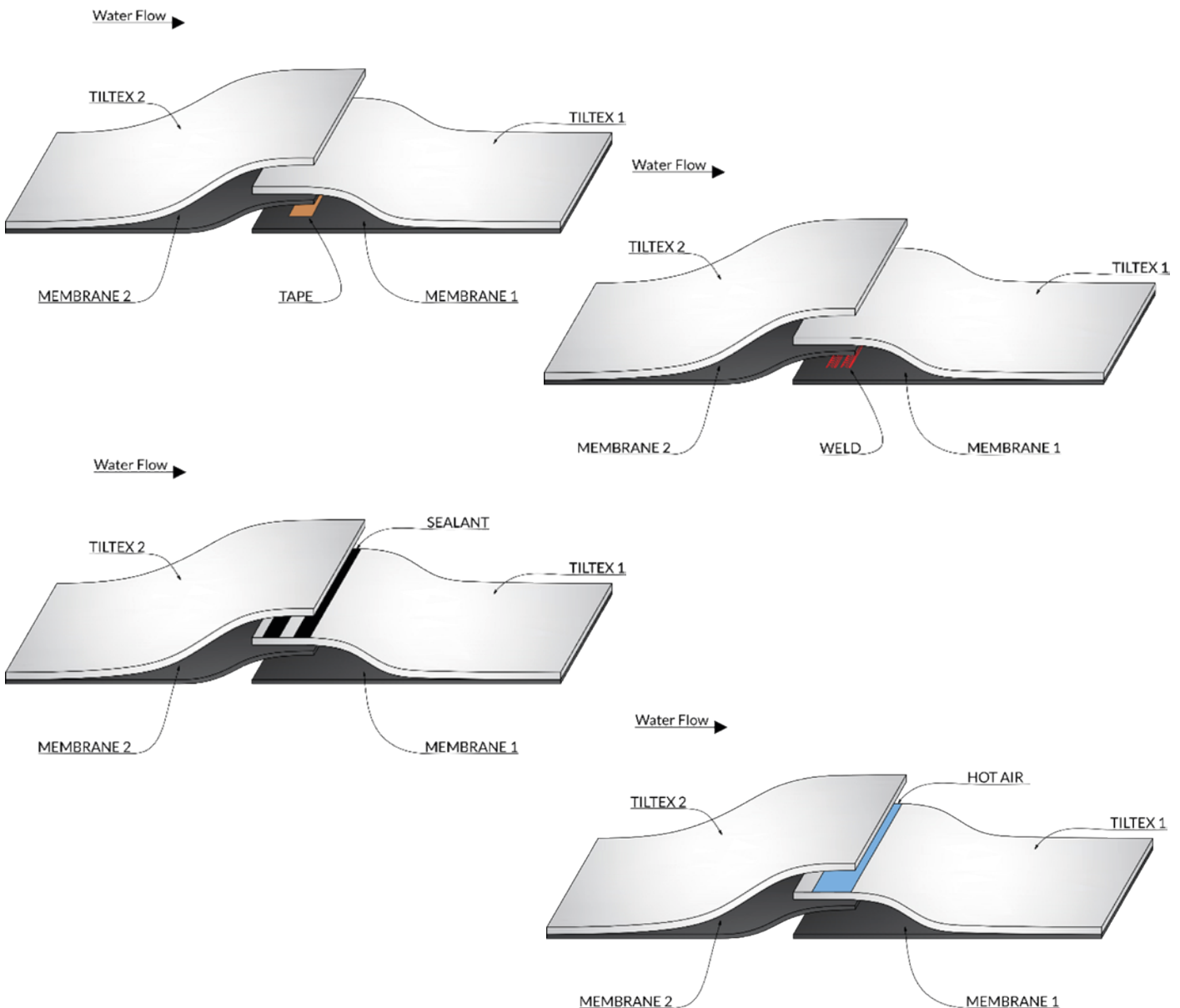

We recommend the use of sealant or hot air gun/gas flame, which is applied after the TILTEX panel is rolled up and before covering it with the panel 2. The overlap welding of the TILTEX panels increases the strength of the bond and maintains a uniform surface of the liner covering.

INSPECTION

11

INSPECTION

After placement (before hydration) an authorized person should perform a thorough visual inspection of the EUROBENT liners rolls and seams.

This should be done immediately after placement is completed.

The inspection should cover overlaps, alignment, penetrations, joints, detection of any defects including installation damage.

Detected Improperly Installed areas should be marked and fixed. Repairs should be inspected and approved by the project engineer or authorized person.

The inspection/repair process should be carried out as soon as possible to ensure that no defective area is left unrepaired.

In order to carry out the inspection correctly, an appropriate form is attached to this manual.



HYDRATING

12

HYDRATING

After fixing and connecting, spray TILTEX with water. The minimum water to liner ratio is 1:2. There is no risk of overhydrating. To ensure sufficient hydration, TILTEX should be re-sprayed after 1 hour from first hydration.

- The minimum water-to-mass ratio of TILTEX is 1:2.
- The best results are obtained using the spraying method.
- The use of a water high pressure on TILTEX may result in damage to the internal structure of the mat, so this should be avoided - we recommend spraying.
- It is recommended to use water that conforms to the mortar water standard (PN-EN 1008: 2004), but water from any source can be used after testing, also sea water.
- TILTEX must not be moved after the hardening process has begun.
- Do not walk on the TILTEX after hydration until it is hard enough.
- Any disturbance of TILTEX after its hydration may result in deterioration of its properties.
- The setting time of TILTEX is 90 minutes after watering.
- The setting time will be reduced in hot climates.
- Depending on outside temperature and quantity of water used for hydration TILTEX hardens within 24 hours but reaches full strength after 28 days.
- If TILTEX is not activated properly, the rehydration process should be repeated.
- The successful hydration of TILTEX depends on the site conditions. For example, in hot weather, the TILTEX should be irrigated more often and with more water, so that the watered surface remains visibly wet for several hours from first hydration.

Hydration at low temperatures:

- When the temperature is below 5°C but above zero, TILTEX should be covered with a protective sheeting (e.g. foil) immediately after hydration.
- If the temperature is likely to fall below 0°C within the next few hours after installation, water with a minimum temperature of 15°C should be used for hydration and a suitable concrete setting accelerator added. Please contact Eurobent for selection of a suitable accelerator.
- We do not recommend installing and hydrating TILTEX at temperatures below - 4 °C or when it is clear that the temperature may drop to this low level within 24 hours.
- Installation of TILTEX on frozen ground is not recommended as ground movement can occur during defrosting and lead to the formation of voids under the mat, which can affect its proper performance.
- Please note that curing TILTEX at temperatures below 0°C may result in weakening of its final properties.

Hydration at high temperatures:

- In hot weather, where rapid evaporation of water can occur, we recommend hydrating TILTEX after sunset, when the temps are already starting to drop.
- After hydration, we recommend covering the TILTEX (e.g. with foil) to reduce evaporation.
- Even after covering with TILTEX, we recommend monitoring the moisture status of the carpet and possibly re-hydrating if the top nonwoven is already dry - this process is crucial in the first 24 hours.



EXAMPLES OF INSTALLATIONS

13

EXAMPLES OF INSTALLATIONS



13.1. Erosion control

TILTEX can be used to provide a hard erosion control surface for rapid protection of slopes, drains, spillways and embankments. TILTEX is typically used as an alternative to conventional concrete, such as shotcrete, and where vegetated slopes are unsuitable due to high flow velocities, dry climates or poor soil conditions.



13.2. Slope protection

TILTEX is suitable for applications where the slope body is naturally stable but the surface is at risk of erosion due to ageing and slippage. A typical example is a sandstone wall or a slope consisting of a mixture of rock and soil, where precipitation leads to a loss of fine particles and threatens to destabilise the slope.



13.3. Slope stabilisation

TILTEX is suitable for applications where the slope body is unstable and there is a risk of deep sliding (when a large mass of the slope collapses). This can be caused by groundwater presents or other factors such as ground vibrations. Conventional solutions include shotcrete, steel grids and soil nails used to stabilise the slope through structural reinforcement. TILTEX can replace shotcrete in such projects, but must be considered as part of a solution designed by a qualified geotechnical engineer.



13.4. Bund lining

TILTEX can be used as a hard erosion control surface for rapid lining of secondary detention basins and flood embankments. TILTEX is typically used as an alternative to turf, which requires regular maintenance, cannot establish itself and poses a fire hazard if it rots. TILTEX is also used to line earthen embankments to protect them from the elements and avoid costly remedial work later to achieve the required height.



13.5. Ditch lining

TILTEX can be used as a hard-wearing erosion protection for the rapid lining of drainage and irrigation ditches. TILTEX is typically used as an alternative to traditional concrete solutions such as poured, sprayed or precast concrete.



13.6. Geomembrane protection

As a layer of reinforced concrete in a roll, TILTEX can be rolled out over the surface of the geomembrane without risking damage to it. Once cured, it becomes an excellent protective layer to prevent puncture of the geomembrane. Covering the geomembrane with TILTEX significantly extends its service life.



13.7. Containment Pond

TILTEX can be unrolled through standing or running water and will cure to meet structural integrity requirements for strength and impermeability.

NOTE:

If it is necessary to anchor TILTEX with a puncture in the geomembrane, contact the TILTEX manufacturer to develop a suitable method to protect the puncture areas to avoid excessive water loss.



EXAMPLES OF INSTALLATIONS

13.8. Suggestions for the right type of TILTEX to use for application

Application	TILTEX 7	TILTEX 9	TILTEX 10	TILTEX 12
Blinding concret	+	+	+	+
Slope erosion control / Studded walls	+	+	+	+
Waterproofing membrane top protection (water tanks)	+	+	+	+
Mechanical protection of underground cables and pipes	+	+	+	+
Water tank concrete surface restoration	+	+	+	+
Stabilization of drilling shafts	+	+	+	+
Ground stabilization	+	+	+	+
Underlay of lines / paving	+	+	+	+
Protection under flexible pools	+	+	+	+
Waterproofing temporary protection	+	+	+	+
Gabion protection	+	+	+	+
Road ditches / nozzles recovery	-	+	+	+
Canals and weirs covering	-	-	+	+
Mechanical protection of membrane under reinforcement (basements)	-	-	-	+
Protection against sea swell	-	-	-	+
Waterproofing membrane top protection (landfills)	-	-	-	+
Maintenance ways on geomembrane	-	-	-	+
Support for vehicle temporary circulation	-	-	-	+

For any installation, the general rules for the installation and use of TILTEX must be followed.

* In all of the above applications where additional waterproofing is required, we recommend the use of TILTEX Plus, which provides excellent waterproofing properties thanks to an additional layer of impermeable PE membrane. Membranes ranging from 0.2 mm to 2.0 mm are available (we can tailor a membrane for the customer on special order).

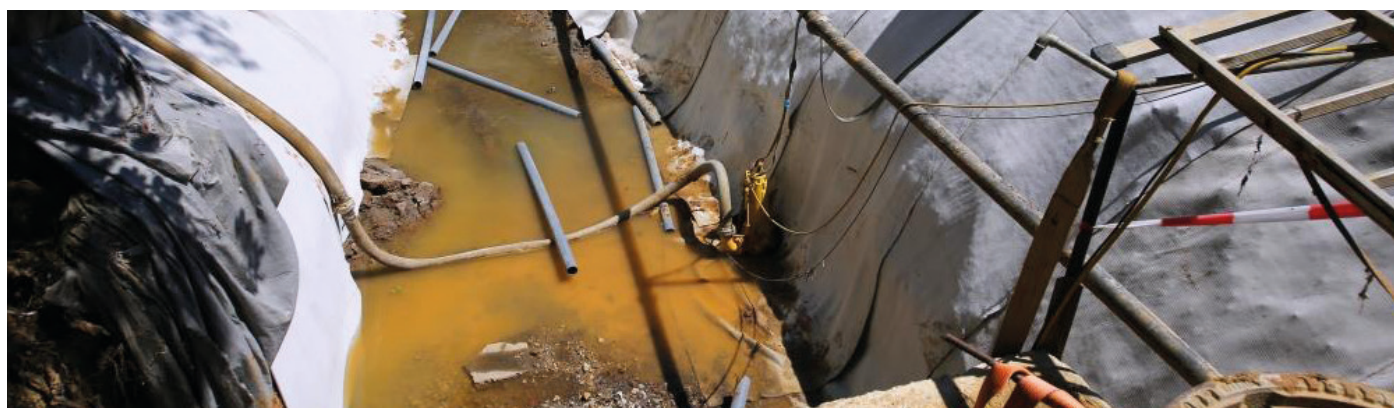

EXAMPLES OF INSTALLATIONS

MAINTENANCE

14

MAINTENANCE

Once TILTEX is installed, there is usually no cleaning or maintenance required.

For example, in channel lining applications, TILTEX covers both banks and slopes, preventing silt build-up and accumulation.

TILTEX has also high resistance to vegetation rooting in the channel, reducing the risk of blockages and subsequent leaks.

However, applications that in their design have features conducting silt buildup in the channel will require periodic cleaning and maintenance to remove impurities.

In all water management applications, the TILTEX surface is a natural substrate for moss growth, but this does not adversely affect the properties of the material.

It can also happen that if the TILTEX panels are not properly bonded, the fine windblown gravel builds up in these spaces and this in turn creates the conditions for unwanted vegetation to grow. This deposit must then be removed, primarily to prevent rooting vegetation from weakening the joint quality and to prevent blockages from forming.

In the case of low-gradient and periodically dry canals, debris carried by the wind, such as leaves, may accumulate in the top, but is most often washed away during e.g. storms; this debris may need to be removed occasionally if the water flow is not sufficient to provide the treatment function.

In any case, periodic inspection of TILTEX lined areas is recommended.

There are three levels of surface maintenance: manual (brushing and snow removal), powered (pressure washing and grubbing) and equipment maintenance (excavators and dredgers).

1

Manual maintenance

A plastic brush can be used to remove debris and sweep it from TILTEX surface. In areas where larger amounts of debris accumulate, a shovel is recommended. Brushing and shoveling should be done in the direction of the overlaps to avoid directing debris into the joints.

2

Powered maintenance

Vacuuming and mechanical water jet spraying can be used on the laid TILTEX mat to remove finer surface debris and unwanted moss growth.

Pressure washing of the top layer of TILTEX should be done very carefully due to the risk of abrasion of the upper surface fibers of the TILTEX.

3

Maintenance with heavy equipment

For larger projects and where location and access allow, it may be practical to use machinery or debris removal equipment, such as an excavator.

However, care must be taken not to damage the TILTEX surface.

Light equipment should be used to dredge TILTEX lined channels and it is important that dredging is carried out by a qualified operator and only in the direction of overlapping joints, taking care not to damage the integrity of the joints and the mat surface.

Ensure that the excavator tracks are kept at least 0.5 m from the channel crown to avoid damage to anchor trenches.

TERMS AND CONDITIONS

15

TERMS AND CONDITIONS

The engineering design for a specific site should be done after the site survey has provided all necessary information.

The evaluation of appropriate safety factors for each specific project must always remain the responsibility of the design engineer.

This manual includes two forms that are helpful for daily installation reports and for TILTEX inspection.

Forms 1 & 2 are attached to the manual.





Goods receipt form

Delivery date		
		Notes*
Container/truck number match the packing list	Yes <input type="checkbox"/> No <input type="checkbox"/>	
Rolls numbers match the packing list	Yes <input type="checkbox"/> No <input type="checkbox"/>	
Condition of packaging (in case of damage, describe the damage in the description section, indicating the roll numbers)	Yes <input type="checkbox"/> No <input type="checkbox"/>	

* If you need to make a note, enter the note number from the description section in this field.

Remarks / non-conformity

.....
Date and signature of the person reporting the installation

Installation form

Project Name/Number	
Installation date	
Weather conditions	
Numbers of installed rolls	

Information about conditions of storage in a yard and on-site.

Rolls covered	Yes <input type="checkbox"/> No <input type="checkbox"/>
Rolls labeled	Yes <input type="checkbox"/> No <input type="checkbox"/>
Packaging damage	Yes <input type="checkbox"/> No <input type="checkbox"/>
Rolls damage	Yes <input type="checkbox"/> No <input type="checkbox"/>
Subgrade surface acceptable	Yes <input type="checkbox"/> No <input type="checkbox"/>
Anchor trenches acceptable	Yes <input type="checkbox"/> No <input type="checkbox"/>
Anchor trench fill compacted	Yes <input type="checkbox"/> No <input type="checkbox"/>
All overlaps visually inspected	Yes <input type="checkbox"/> No <input type="checkbox"/>
Joining overlaps correct	Yes <input type="checkbox"/> No <input type="checkbox"/>
All detail work inspected	Yes <input type="checkbox"/> No <input type="checkbox"/>
Proper hydration	Yes <input type="checkbox"/> No <input type="checkbox"/>

*If there are defects or deficiencies that need to be noted, use the Remarks section.

.....
Date and signature of the person reporting the installation

Remarks

.....
Date and signature of the person reporting the installation



eurobent

KEEP ROLLING

Tiltex
SYSTEM

Eurobent Sp. z o.o.
Kliczkowska 42
58-100 Świdnica
Poland

tel. +48 74 852 13 19
www.eurobent.com
www.tiltexsystem.com
office@eurobent.com